

Gain-Master™ HW

Hi-Tech Fiberglass Base Station Antenna for Ham band



Gain-Master™ HW is a **Half Wave** high tech fiberglass base station antenna for 10m to 11m amateur band made of telescopic fiberglass tubes. Engineered with the most advanced available technologies it is completely manufactured in Italy with high quality materials. The design of the radiant element works like a central fed dipole so all RF currents on the radiator are in-phase and the **ground plane radials are not necessary**. The coaxial coil at the bottom works like RF-choke for the optimum decoupling from mast and feeding line.

WARNING

INSTALLATION OF THIS PRODUCT NEAR POWER LINES IS DANGEROUS. FOR YOUR SAFETY AND BEFORE YOU BEGIN INSTALLATION, READ THE SEPARATE SAFETY INFORMATION SHEET.

Electrical Data

Type	0.5 λ center fed vertical dipole
Frequency Range	27.2 - 30 MHz (see tunable table pag.3)
Bandwidth @ SWR \leq 2.0	1.8 MHz @ 27.2 MHz
Impedance	50 Ω
Radiation	Omnidirectional
Polarization	Linear Vertical
Max Gain on the horizon	0 dBd
Max Power	500 Watts (CW) continuous
Connector	UHF-female, PTFE insulator & gold plated central pin

Mechanical Data

Materials	Whip made of white fiberglass three sections composite tube, radiator made of copper wire and low loss coax cable, stainless steel hardware, anodized AW6060 aluminium, UV stabilized thermoplastic
Wind Resistance	up to 160 Km/h; 100 mi/h
Height (approx.)	5560 mm; 11.2 ft with bracket
Packaging Dimensions	1950x100x130 mm; 77x4x5 in
Weight (approx.)	2.6 Kg; 5.7 lb
Mounting mast	\varnothing 35-54 mm; \varnothing 1.4-2.1 in side mast with "V" bolt

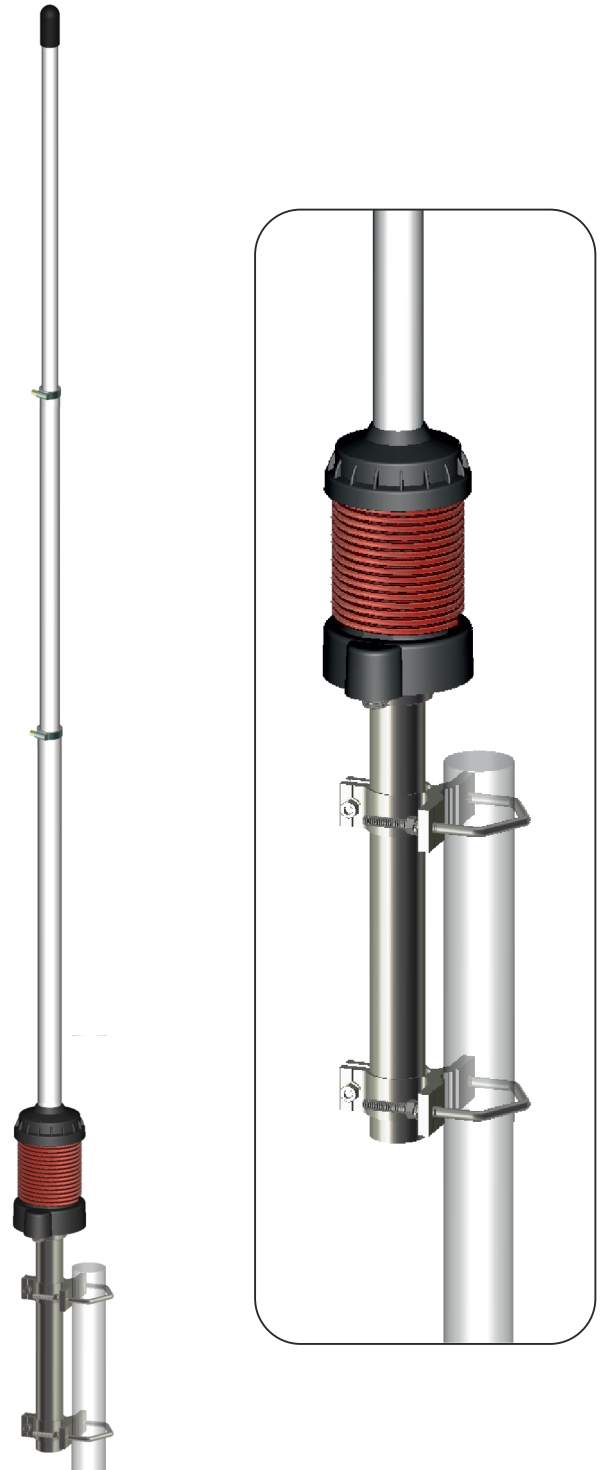



ITALIANO

Gentile Cliente, vogliamo ringraziarla per aver acquistato un antenna SIRIO Gain-Master™ HW, siamo sicuri che le darà grandi soddisfazioni perché è stata progettata con le più avanzate tecnologie attualmente disponibili ed è costruita interamente in Italia con materiali di elevata qualità.

Gain-Master™ è il concentrato di quarant'anni di esperienza nel campo delle antenne che ci ha permesso di sviluppare prodotto unico che rimarrà uno standard di riferimento per molti anni a venire.

Come funziona Gain-Master™ HW

Come mostrato in Fig.1 il segnale RF proveniente dal generatore percorre il cavo coassiale della bobina d'arresto, quindi prosegue lungo lo stilo fino ad arrivare alla terminazione della linea coassiale (centro di fase dell'antenna). Da questo punto la parte di segnale presente sul conduttore centrale si propaga lungo la metà superiore della parte radiante mentre le correnti RF, che viaggiavano all'interno della schermatura del cavo, fuoriescono scorrendo all'esterno della schermatura e ridiscendono verso la bobina d'arresto dove l'elevata impedenza della bobina fa sì che si arrestino (funzionamento equivalente ad un dipolo alimentato nel suo centro).

In Fig.2 è illustrata la distribuzione di corrente di SIRIO Gain-Master™ HW. La parte radiante si comporta come un dipolo alimentato al centro, di conseguenza tutte le correnti RF risultano in fase e concordi tra loro. Questo accorgimento ci ha permesso di avere un diagramma di irradiazione identico ad un dipolo con il suo massimo del segnale nel piano orizzontale. Gain-Master™ HW presenta quindi il massimo guadagno ottenibile per un'antenna $1/2\lambda$ e grazie al suo angolo di radiazione perfettamente orizzontale permette i migliori collegamenti possibili.

Altri vantaggi di Gain-Master™ HW sono:

È realizzata e assemblata completamente in Italia con i migliori materiali disponibili, a partire dallo stilo che è realizzato in tre sezioni da 1.92m di tubi telescopici composti in fibra di vetro con parete a triplo strato che rende Gain-Master™ HW molto più resistente e rigida rispetto alle concorrenti.

Non necessita di radiali ground plane in quanto è un'antenna bilanciata che funziona come un dipolo alimentato al centro. Grazie alla sua bobina di arresto (RF-Choke) posta alla base, Gain-Master™ HW risulta perfettamente disaccoppiata dalla sua struttura di sostegno (pali, tralicci, etc.) con il beneficio di mantenere inalterati sia l'impedenza che il diagramma di irradiazione.

Può essere tarata nella banda da 27.2 a 30 MHz tramite tabella di sintonia.

Accetta una potenza massima continuata di 500Watts RMS.



ENGLISH

Dear Customer, we thank you for purchasing a SIRIO Gain-Master™ HW antenna, we are sure you will give great satisfaction because it was designed with the most advanced technologies currently available and it's entirely built in Italy with high quality materials.

Gain-Master™ HW is the result of four decades of experience in the antennas field; that allowed this unique product that will remain a standard reference for many years to come.

How Gain-Master™ HW works

As shown in Fig.1 the RF signal started from the generator run through the coaxial cable of the choke coil, then continue along the first part of the whip until it meet the termination of the coaxial line (antenna phase centre).

At this point, the signal on the inner conductor propagates along the upper half of the radiation element. The RF current travelling inside the cable shield, protruding outside the screen and descend toward the choke coil where the high impedance stop it (in fact, it's equivalent to a centre-fed dipole).

Fig.2 shows the current distribution of SIRIO Gain-Master™ HW. The design of radiant element behaves as a centre-fed dipole, hence all currents are in phase.

This arrangement allowed us to have a radiation pattern equal to a dipole which has its maximum gain on the horizon. Gain-Master™ HW has the highest available gain for $1/2\lambda$ antenna and due to its angle of radiation perfectly horizontal, enables the best possible connections.

Other Gain-Master™ HW advantages are:

It's completely made and assembled in Italy with the finest materials available, starting from the whip which is carried out in three sections of 1.92m telescopic tubes with triple-layer fibreglass.

It makes Gain-Master™ HW much more durable and rigid then the competitors.

It does not require ground plane radials because it is a balanced antenna that function as a centre-fed dipole.

Thanks to it's cable coil (RF-Choke) at the base, Gain-Master™ HW is fully decoupled from its supporting structure (poles, towers, etc.) with the benefit of preserving both the impedance that the radiation pattern.

It can be tuned in the range from 27.2 to 30MHz using the tuning table.

It accepts a maximum continuous power of 500Watts RMS.

Gain-Master™ HW Technical Informations

SAFETY FIRST: YOU CAN BE KILLED IF THIS ANTENNA COMES NEAR ELECTRIC POWER LINES. BEFORE DOING INSTALLATION, READ THIS MANUAL AND THE SUPPLIED SEPARATE SAFETY MULTI LANGUAGE INFORMATION SHEET.

SUGGESTION: We recommend to assemble the antenna on a flat ground open area. Use a good coax cable like BELDEN H1000R, AIRCOM PLUS or RG-213 as short as possible to get the best performance and we recommend to mount your antenna at minimum 3 meters above the roof, as far as possible from walls, power lines and other antennas.

TROUBLESHOOTING: Gain-Master HW is a tunable antenna. It is factory checked one by one. If you are unable to obtain an acceptable SWR reading from your antenna, follow these suggestions to try to solve the problem.

Check the coaxial cable and all its connections. Be sure that the cable is not pinched, shorted, broken or kinked.

Check if the equipments (CB radio and SWR-meter) work properly. Make use of owner's manual for assistance in operating it.

Be sure that the antenna is installed at least 3 meters above the roof of the nearest building and 5-6 meters above or away from any metal objects in the area.

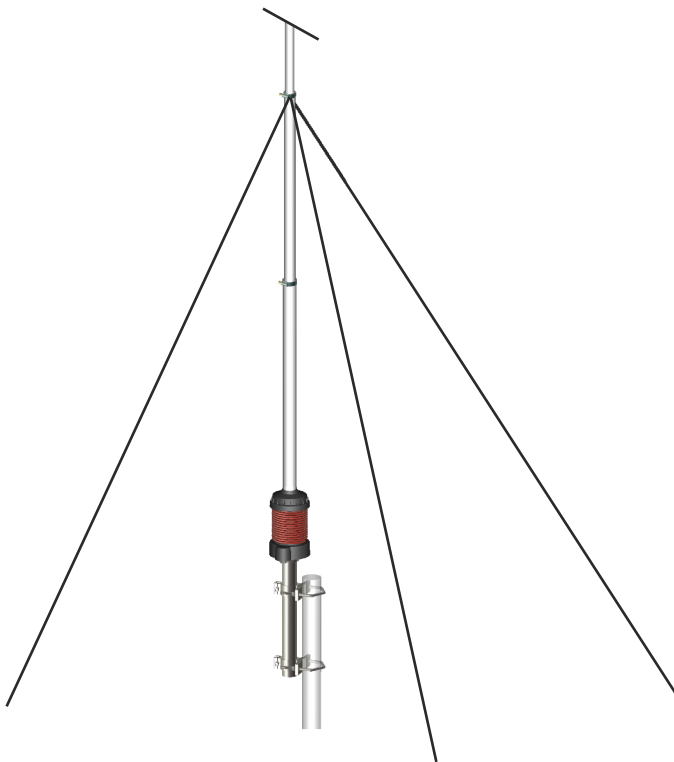

ATTENTION: Important for a proper installation

In order to avoid excessive stress and possible damages to your GainMaster, we recommend to make use of bracing rods for the installation in hazardous areas such as:

- Locations subjected to strong wind or constant gusts of wind (eg: coast and mountain areas).
 - Locations with cold winter conditions and frequent formation of ice layers on the antenna body. In fact, the different distribution of the weight, can change substantially the resistance to the wind.
- We therefore recommend at least 3 ties "NYLON" bracing to be fixed at the junction between 2° and 3° fiber pipe (see drawing).

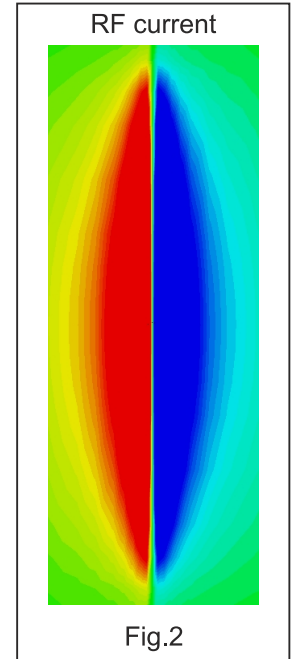
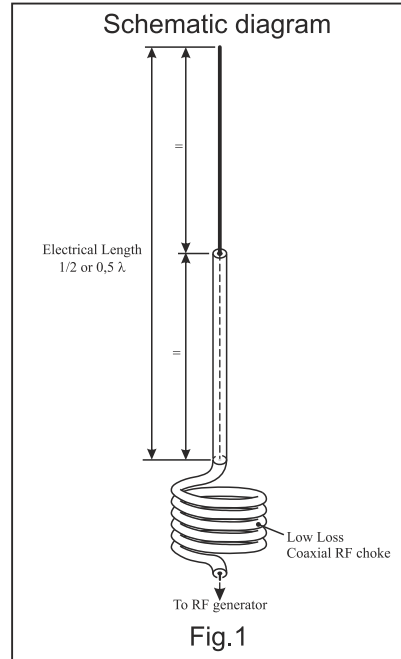

TUNING TABLE

Frequency (MHz)	L = (mm)	Band @ SWR=2
27.2	1820	26.3 ÷ 28.1 MHz
27.5	1783	26.6 ÷ 28.4 MHz
28.0	1734	27.1 ÷ 28.9 MHz
10m band 28.5	1692	27.6 ÷ 29.4 MHz
29.0	1647	28.0 ÷ 30.0 MHz
29.5	1611	28.5 ÷ 30.5 MHz
30.0	1550	29.0 ÷ 31.0 MHz

NOTE: Use the table just as a guide. For fine-tuning please use an SWR-meter

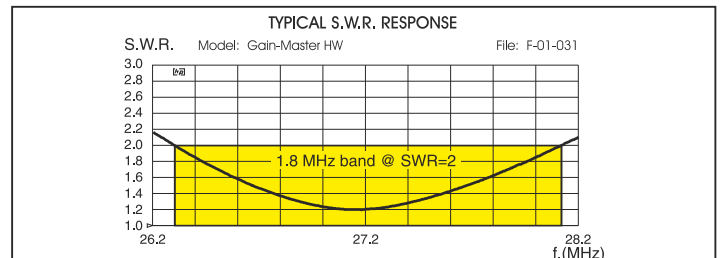

Parts List

Pos	Q.ty	Part No	Description
1	1	SL06600	Wired coaxial radiator
2	1	-	Bottom section with coil
3	1	CH01407	8mm open key
4	1	CF02117	15.4x19x1920 fiberglass tube
5	1	CF02217	19.5x23.5x1920 fiberglass tube
6	2	FA00200	Ø 16-27mm AISI316 hose clamps
7	1	TE07300	Ø 18.8x17 radiator fixing part
8	1	VT05900	M4x6 AISI304 set screw cone point
9	1	CH00800	2 mm Allen key
10	1	TE05616	Ø 18.8 PVC top cap
11	1	IE560/USA	self-adhering "DANGER" label
12	2	VT01300	M6x20 AISI304 exagonal head screw
13	2	ST04500	Extruded aluminium bracket
14	2	TI03100	M6x188 AISI304 V-bolt
15	6	DA01400	M6 AISI304 hexagonal nut
16	6	RO04200	M6 AISI304 spring lock washer

Gain-Master™ HW Mounting Instructions

Fase/Step 1

- Connessione del cavo radiante
Connection of wired radiator

Mounting needed tools:

- n. 1 tape rules (meter)
- n. 1 screwdriver flat point
- n. 1 10 mm open jaw wrench
- n. 1 plier
- n. 1 electrical PVC tape
- n. 1 nippers

1

Avvitare i connettori
BEN SERRATI!
Screw on the connectors
WELL LOCKED!

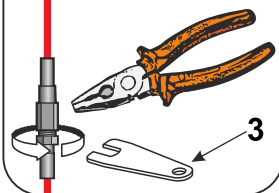

Sigillare entrambi i connettori con nastro adesivo in PVC
Seal both connectors with electrical PVC tape

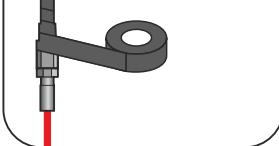

ATTENZIONE!
Non piegare o schiacciare il cavo coassiale
ATTENTION!
Do not bend or pinch the coaxial cable.

2

Fase/Step 2

- Inserimento tubi sul cablaggio
Insert the tubes on wiring

- Scegliere la frequenza di lavoro dalla Tabella di Taratura a pag.3, quindi posizionare i tubi alla lunghezza *L corrispondente
*Choose the working frequency from the Tuning Table on page 3, then place the tubes to length *L corresponding*

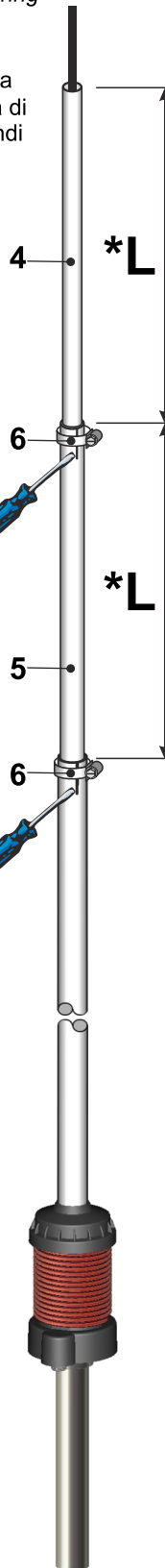

- Serrare le fascette 6 fino al bloccaggio dei tubi in fibra 4 e 5.
ATTENZIONE: un serraggio eccessivo può provocare crepe e danni ai tubi in fibra.
Tighten the clamps 6 up to the locking of the fiberglass tubes 4 and 5.
CAUTION: A over-tightening it may cause cracks and damage at the fiberglass tubes.

*L = see Tuning Table pag.3

Fase/Step 3

- Infilare parte 7 sul cavo fino in battuta
Insert part 7 on cable until it stops

- Tendere il cavo quindi farlo rientrare di 1÷1.5cm.
Pull up the cable then return down 1÷1.5cm.

NOTA: IL CAVO NON DEVE ESSERE TESO
REMARK: THE CABLE MUST NOT BE TIGHT

- **Bloccare con forza** il cavo con vite 8 e chiave 9
Lock strongly the cable with screw 8 and key 9

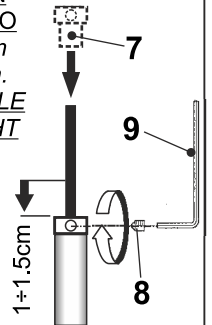

Fase/Step 4

- Tagliare il cavo in eccesso
Cut the extra cable

- Installare il cappuccio in PVC
Instal the PVC cap

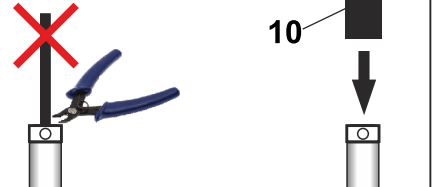

Fase/ Step 5

- Applicare l'etichetta DANGER in un punto visibile
Apply the DANGER sticker in a visible point



11

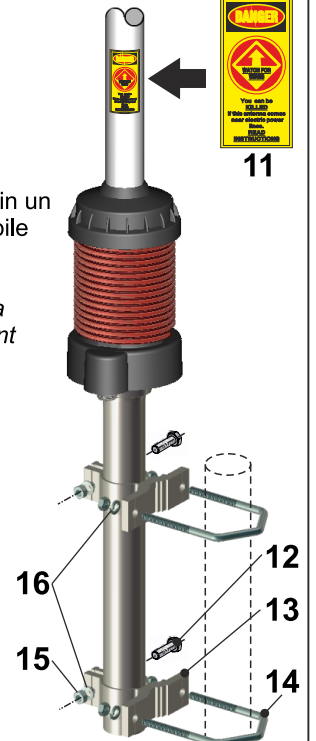

Robusto palo di montaggio
Ø 35-54mm (non fornito)

Strong steel mast
Ø 35-54mm (not supplied)